

Better Pumps for Better Yield!

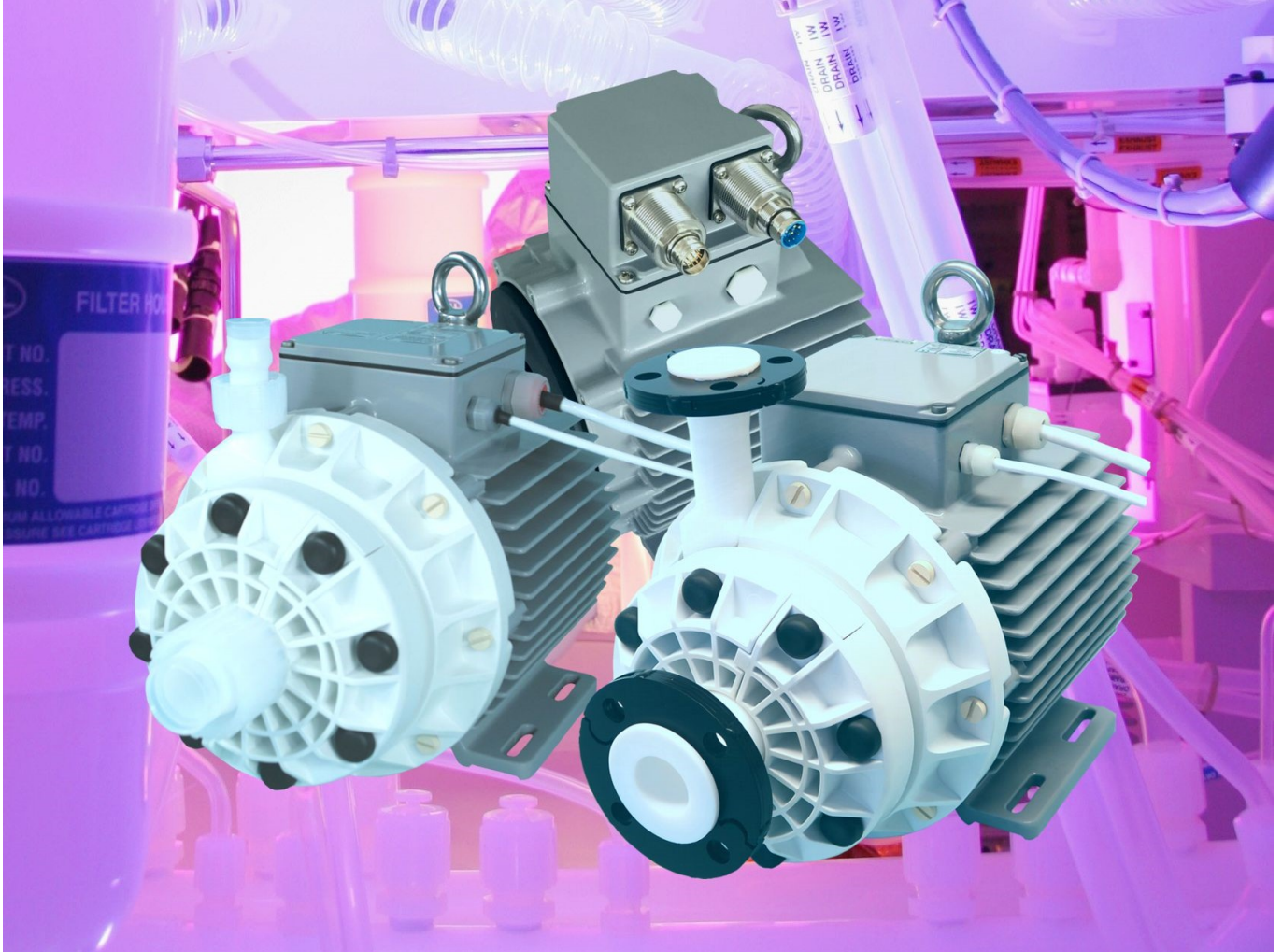

**No Seals, No Bearings,
No Particle Contamination!**

BPS-4000

6.3 bar (91 psi)
280 liters/min (74 gallons/min)

**Levitronix® MagLev Pump Technology
Better Pumps for Better Yield!**

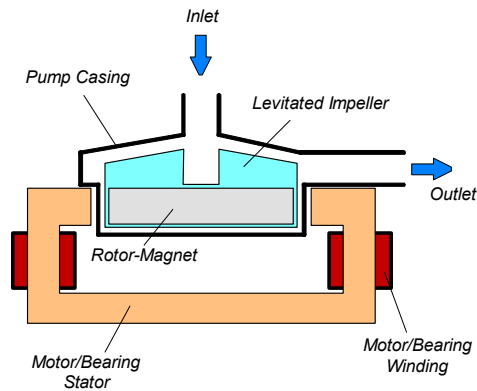

Figure 1: Schematic of maglev centrifugal pump

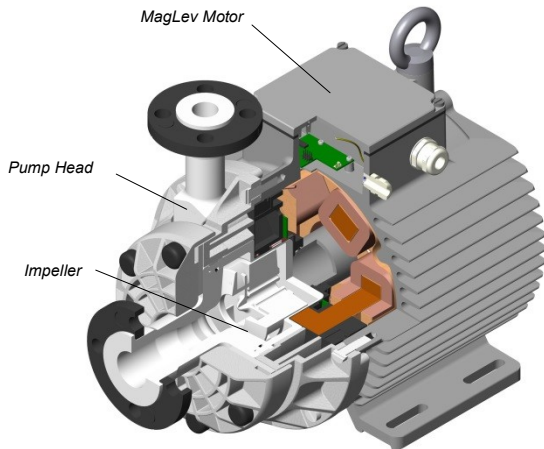

Figure 2: Maglev motor with pump head LPP-4000.4/5

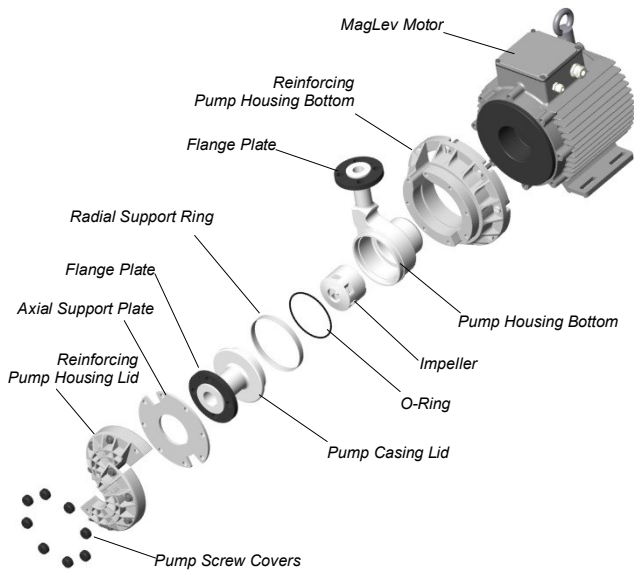

Figure 3: Disassembled pump head LPP-4000.4/5

REVOLUTIONARY MAGNETICALLY LEVITATED CENTRIFUGAL PUMP

The BPS-4000 pump system is a revolutionary centrifugal pump that has no bearings to wear out or seals to break down and fail. Based on the principles of magnetic levitation, the pump's impeller is suspended, contact-free, inside a sealed casing and is driven by the magnetic field of the motor (Figure 1). The impeller and casing are both fabricated from chemical-resistant high purity fluorocarbon resins. Together with the rotor magnet they make up the pump head. Fluid flow rate and pressure are precisely controlled by electronically regulating the impeller speed and eliminating pulsation.

SYSTEM BENEFITS

- Extremely low particle generation due to the absence of mechanically contacting parts. Reduces particle contamination issues in wet processes by generating 10 to 50 times fewer particles compared to other pumps.
- Increases equipment uptime.
- Lower maintenance costs by eliminating valves, bearings, rotating seals and costly rebuilds.
- Reduced risk of contamination due to the self-contained design with magnetic bearings.
- Very gentle to sensitive fluids due to low-shear design.
- No narrow gaps and fissures where particles or micro-organisms could be entrapped.
- Smooth, continuous flow without pressure pulsation.
- Electronic speed control.
- Compact design compared to pneumatic and magdrive pumps. Saves valuable space in process tools by having a smaller footprint.
- Proven technology in medical and semiconductor industry (MTBF > 30 years).

APPLICATIONS

- Semiconductor wet processing.
- Solar cell production.
- Flat panel display manufacturing.
- Hard-disk fabrication.
- Printer ink handling.
- Pharmaceutical production.

STAND-ALONE SYSTEM CONFIGURATION

The stand-alone configuration of the BPS-4000 pump system (see Figure 6) consists of a controller with an integrated user panel allowing the operator to set the speed manually. The speed is automatically stored in the internal EEPROM of the controller. As an option, the speed can also be set with an analog signal (see specification for Position 3a in Table 2).

EXTENDED SYSTEM CONFIGURATION

The extended version of the BPS-4000 pump system (Figure 7) consists of a controller with an extended PLC interface. This allows setting the speed by an external signal (see specification of Position 3b in Table 2) and enables precise closed-loop flow or pressure control in connection with either a flow or a pressure sensor. A USB interface allows communication with a PC in connection with the Levitronix® Service Software. Hence parameterization, firmware updates and failure analysis are possible.

ATEX/IECEx SYSTEM CONFIGURATION

An ATEX/IECEx certified motor together with the pump head allows installation of motor and pump head within an ATEX Zone 2 area (see Figure 8). The ATEX motor (Pos. 2b in Table 2) comes with special connectors and relevant extension cables (Pos. 5a and 5b in Table 3). An ATEX conform solution is needed for the motor cables to leave the ATEX area. One option is an ATEX certified cable sealing system as listed in Table 4 (see Pos. 9) and shown in Figure 12.

HAZLOC SYSTEM CONFIGURATION

A Hazardous Location NRTL certified motor together with the pump head allows installation of motor and pump head within a Class I Division 2 area (see Figure 8). The HazLoc motor (Pos. 2c in Table 2) comes with special connectors and NPT threads on the motor housing to attach a conduit for the cables to leave the hazardous location area.

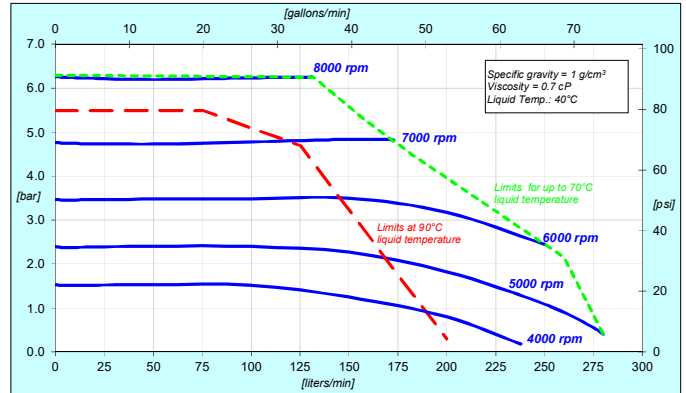

Figure 4: Pressure/flow curves
Typical curves measured with pump head LPP-4000.5.

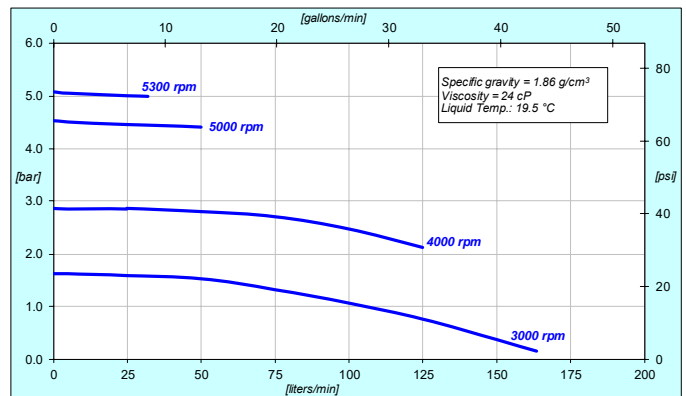

Figure 5: Pressure/flow curves for high density/viscosity liquids
Typical curves measured with pump head LPP-4000.5.

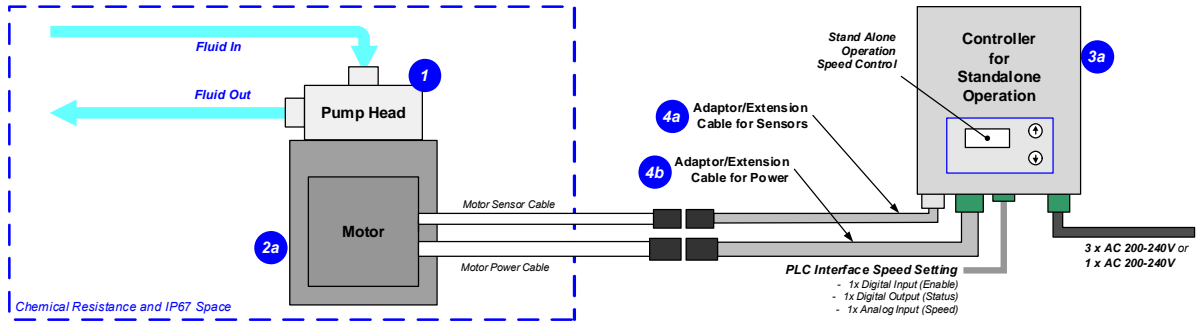

Figure 6: System configuration for standalone operation (speed setting with integrated user panel)

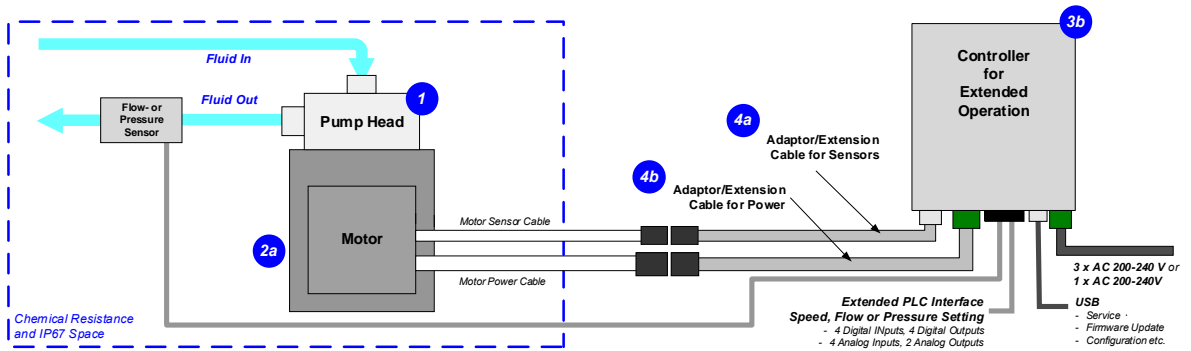

Figure 7: Extended operation (flow or pressure control) with extended controller

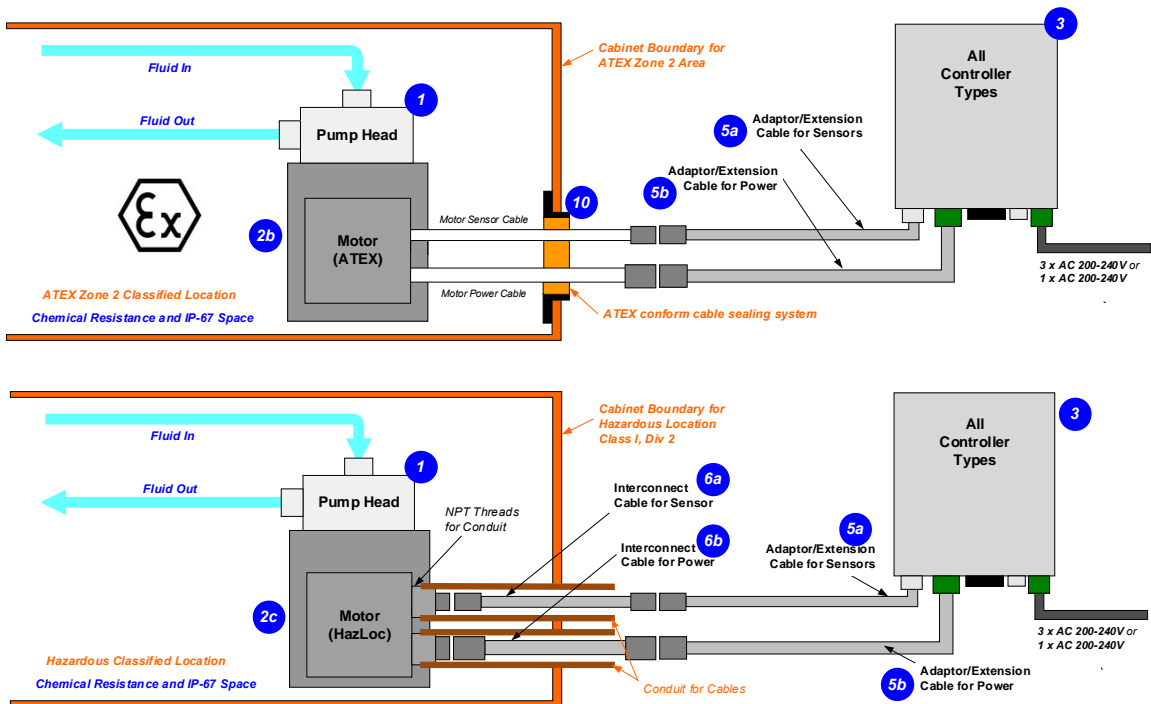

Figure 8: System Configuration for ATEX and Hazardous Location applications

DIMENSIONS OF MAIN COMPONENTS

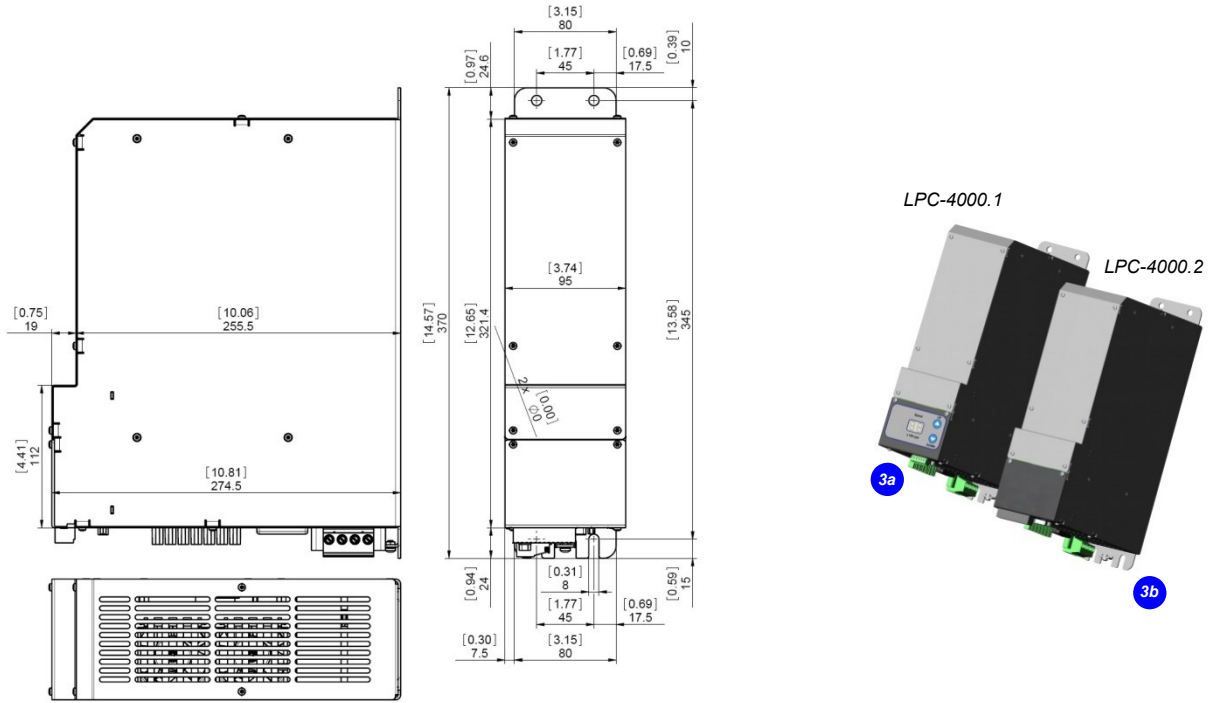

Figure 9: Basic dimensions of controllers LPC-4000.x

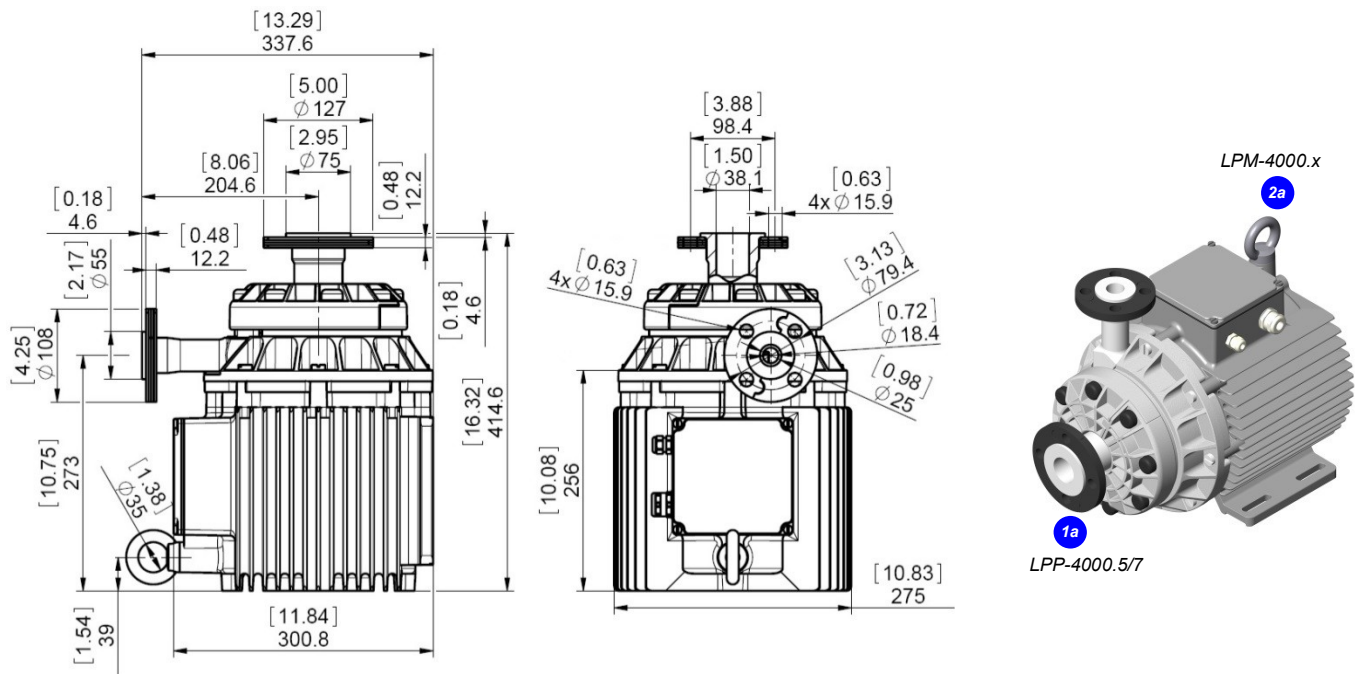

Figure 10: Dimensions of motor LPM-4000.x with pump heads LPP-4000.5/7
 Drawings with pump heads LPP-4000.6/8 (Pillar fittings) and drawings with hazardous location motors are available on request.



www.levitronix.com

Bearingless Pump System BPS-4000 MagLev Pumps for Ultrapure Fluid Handling

ORDER INFORMATION

System Name	Article #	Pump Head	Motor	Controller	Note
BPS-4000.27 BPS-4000.28	100-90962 100-90963	LPP-4000.5 (ECTFE Impeller, Flange Fittings)	LPM-4000.2	LPC-4000.1 LPC-4000.2	Adaptor/Extension (0.5 – 10 m) cables according to Table 3 (positions 4a and 4b) have to be ordered as separate articles. Certifications: CE, IECEx CB scheme, ETL (NRTL).
BPS-4000.30 (ATEX) BPS-4000.31 (ATEX)	100-90965 100-90966		LPM-4000.8 (ATEX)	LPC-4000.1 LPC-4000.2	Adaptor/Extension (0.5 – 10 m) cables according to Table 3 (positions 5a and 5b) have to be ordered as separate articles. Certifications: CE, IECEx CB scheme, ETL (NRTL), ATEX and IECEx.
BPS-4000.52 (HazLoc) BPS-4000.53 (HazLoc)	100-91162 100-91163	LPP-4000.6 (ECTFE Impeller, Pillar Fittings)	LPM-4000.10 (HazLoc)	LPC-4000.1 LPC-4000.2	Adaptor/Extension (0.5 – 10 m) cables according to Table 3 (see also Figure 8) have to be ordered as separate articles. Certifications: CE, IECEx CB scheme, ETL (NRTL), HazLoc CH Div2
BPS-4000.47 BPS-4000.48	100-91157 100-91158		LPM-4000.2	LPC-4000.1 LPC-4000.2	Adaptor/Extension (0.5 – 10 m) cables according to Table 3 (positions 4a and 4b) have to be ordered as separate articles. Certifications: CE, IECEx CB scheme, ETL (NRTL).
BPS-4000.49 (ATEX) BPS-4000.46 (ATEX)	100-91159 100-91149	LPP-4000.7 (PFA Impeller, Flange Fittings)	LPM-4000.8 (ATEX)	LPC-4000.1 LPC-4000.2	Adaptor/Extension (0.5 – 10 m) cables according to Table 3 (positions 5a and 5b) have to be ordered as separate articles. Certifications: CE, IECEx CB scheme, ETL (NRTL), ATEX and IECEx.
BPS-4000.50 (HazLoc) BPS-4000.51 (HazLoc)	100-91160 100-91161		LPM-4000.10 (HazLoc)	LPC-4000.1 LPC-4000.2	Adaptor/Extension (0.5 – 10 m) cables according to Table 3 (see also Figure 8) have to be ordered as separate articles. Certifications: CE, IECEx CB scheme, ETL (NRTL), HazLoc CH Div2
BPS-4000.64 BPS-4000.65	100-91250 100-91251	LPP-4000.7 (PFA Impeller, Flange Fittings)	LPM-4000.2	LPC-4000.1 LPC-4000.2	Adaptor/Extension (0.5 – 10 m) cables according to Table 3 (positions 4a and 4b) have to be ordered as separate articles. Certifications: CE, IECEx CB scheme, ETL (NRTL). Note: Includes Eyebolt Seal Set (see Table 4)
BPS-4000.67 (ATEX) BPS-4000.68 (ATEX)	100-91253 100-91254		LPM-4000.8 (ATEX)	LPC-4000.1 LPC-4000.2	Adaptor/Extension (0.5 – 10 m) cables according to Table 3 (positions 5a and 5b) have to be ordered as separate articles. Certifications: CE, IECEx CB scheme, ETL (NRTL), ATEX and IECEx. Note: Includes Eyebolt Seal Set (see Table 4)
BPS-4000.70 (HazLoc) BPS-4000.71 (HazLoc)	100-91256 100-91257	LPP-4000.8 (PFA Impeller, Pillar Fittings)	LPM-4000.10 (HazLoc)	LPC-4000.1 LPC-4000.2	Adaptor/Extension (0.5 – 10 m) cables according to Table 3 (see also Figure 8) have to be ordered as separate articles. Certifications: CE, IECEx CB scheme, ETL (NRTL), HazLoc CH Div2 Note: Includes Eyebolt Seal Set (see Table 4)
BPS-4000.73 BPS-4000.74	100-91259 100-91260		LPM-4000.2	LPC-4000.1 LPC-4000.2	Adaptor/Extension (0.5 – 10 m) cables according to Table 3 (positions 4a and 4b) have to be ordered as separate articles. Certifications: CE, IECEx CB scheme, ETL (NRTL). Note: Includes Eyebolt Seal Set (see Table 4)
BPS-4000.76 (ATEX) BPS-4000.77 (ATEX)	100-91262 100-91263	LPP-4000.8 (PFA Impeller, Pillar Fittings)	LPM-4000.8 (ATEX)	LPC-4000.1 LPC-4000.2	Adaptor/Extension (0.5 – 10 m) cables according to Table 3 (positions 5a and 5b) have to be ordered as separate articles. Certifications: CE, IECEx CB scheme, ETL (NRTL), ATEX and IECEx. Note: Includes Eyebolt Seal Set (see Table 4)
BPS-4000.79 (HazLoc) BPS-4000.80 (HazLoc)	100-91165 100-91166		LPM-4000.10 (HazLoc)	LPC-4000.1 LPC-4000.2	Adaptor/Extension (0.5 – 10 m) cables according to Table 3 (see also Figure 8) have to be ordered as separate articles. Certifications: CE, IECEx CB scheme, ETL (NRTL), HazLoc CH Div2. Note: Includes Eyebolt Seal Set (see Table 4)

Table 1: Standard system configurations

Pos.	Component	Article Name	Article #	Characteristics	Value / Feature
1a 1b	Pump Head (ECTFE Impeller)	LPP-4000.5 (Flange) LPP-4000.6 (Pillar)	100-90960 100-91123	Impeller / Pump Housing Sealing Ring Fittings Type / Size Max. Flow / Max. Diff. Pressure Max. Viscosity / Density	ECTFE / PTFE (wet parts), reinforcement of housing with PP+GF and SS+PTFE Kalrez® perfluoroelastomer ¹ ANSI flange or Pillar Super 300 / 1.5" inlet and 1" outlet 280 liters/min / 74 gallons/min / 6.3 bar / 91 psi 30 cP / 1.8 g/cm ³
1c 1d	Pump Head (PFA Impeller)	LPP-4000.7 (Flange) LPP-4000.8 (Pillar)	100-91242 100-91241	Impeller / Pump Housing Fittings Type / Size	Full performance: 70 °C / 158 °F. Reduced performance: 70-90 °C / 158-194 °F (see Figure 4).
2a	Motor	LPM-4000.2	100-10043	Housing Cable / Connectors	ETFE coated aluminum, waterproofed (IP67 without connectors) 2x 3 m long cables with FEP jacket / 2x circular connectors (AMP types)
2b	Motor (ATEX, IECEx)	LPM-4000.8	100-10048	ATEX/IECEx Marking Cable / Connectors	CE (E) II 3G Ex ec h mc IIC T4 Gc / CE (E) II 3D Ex h tc IIC T105°C Dc 2x 3m cables with FEP jacket / 2x circular (M23, IP67)
2c	Motor (HazLoc)	LPM-4000.10	100-10115	Hazardous Location Marking Connectors	Class I, Div2, Groups A-D T5 Class II, Div2, Groups E-G T5 2x circular (M23, IP67) / NPT 1/4" for cable protection conduit
3a	Standalone Controller (User Panel)	LPC-4000.1	100-90370 (Connectors included)	Voltage / Electrical Power Interfaces for Standalone Controller	1 x 200-240 VAC or 3x 200-240VAC ±10%, 50/60 Hz / 4 kW Panel to set speed (automatic storage on internal EEPROM) PLC with 1x analog input ("Speed") 4 – 20 mA 1x digital input ("Enable") 0 – 24 V (optocoupler) 1x digital output ("Status") 0 – 24 V (relay)
3b	Extended Controller (PLC and USB)	LPC-4000.2	100-90371 (Connectors included)	Interfaces for Extended Controller	4 digital inputs with 0 – 24 V (optocoupler) 4 digital outputs with 0 – 24 V (relay) 2 analog inputs with 4 – 20 mA 2 analog outputs with 0 – 10 V USB interface (for service and system monitoring)

Table 2: Specification of standard components (Note 1: Kalrez® is a registered trademark of DuPont Dow Elastomers)

Pos.	Component	Article Name		Article #		Characteristics	Value / Feature
		Sensor Cable (a)	Power Cable (b)	Sensor (a)	Power (b)		
4a 4b	Extension Adaptor Cable for Sensor (a) and Power (b)	MCAS-600.1-05 (0.5 m) MCAS-600.1-30 (3 m) MCAS-600.1-50 (5 m) MCAS-600.1-70 (7 m) MCAS-600.1-100 (10 m)	MCAP-4000.1-05 MCAP-4000.1-30 MCAP-4000.1-50 MCAP-4000.1-70 MCAP-4000.1-100	190-10122 190-10123 190-10124 190-10124 190-10125	190-10172 190-10173 190-10174 190-10175 190-10176	Jacket Material Connector Types Connector Material	PVC Circular AMP to D-SUB Plastics (PA)
5a 5b	Extension Adaptor Cable for Sensor (a) and Power (b) Wires	MCAS-600.3-05 (0.5 m) MCAS-600.3-30 (3 m) MCAS-600.3-50 (5 m) MCAS-600.3-70 (7 m) MCAS-600.3-100 (10 m)	MCAP-4000.2-05 MCAP-4000.2-30 MCAP-4000.2-50 MCAP-4000.2-70 MCAP-4000.2-100	190-10158 190-10159 190-10130 190-10130 190-10180 190-10183 190-10184	190-10180 190-10181 190-10182 190-10183 190-10184	Jacket Material Connector Types Connector Material	PVC Circular M23 (IP67) to D-SUB Metallic – Nickel coated
6a 6b	Interconnect Cable for Sensor (a) and Power (b) Wires	MCIS-2000.1-05 (0.5 m) MCIS-2000.1-30 (3 m) MCIS-2000.1-50 (5 m) MCIS-2000.1-70 (7 m) MCIS-2000.1-100 (10 m)	MCIP-4000.1-05 MCIP-4000.1-30 MCIP-4000.1-50 MCIP-4000.1-70 MCIP-4000.1-100	190-10391 190-10392 190-10393 190-10394 190-10395	190-10402 190-10403 190-10404 190-10405 190-10406	Jacket Material Connector Types Connector Material	PVC Circular M23 (IP67) to Circular M23 Metallic – Nickel coated

Table 3: Specification of adaptor/extension cables

Pos.	Component	Article Name	Article #	Characteristics	Value / Feature
7a	Air Cooling Module	ACM-4000.1	190-10177	Material / Connection Port Air Pressure	PP / NPT 1/2" ~1 - 3 bar (14 – 43 psi)
7b	Air Cooling Module	ACM-4000.3	190-10190	Material	PP with conductive additive for operation with ATEX motor
8	Fan Cooling Module	FCM-4000.1	190-10178	Housing / Cable Material Supply Spec. / IP Rating	PP (+ 40% Talcum) / PVC, 6 m, open-end wires 20.4 – 27.6 VDC, 31.2 W, 1.3 A / IP65
9a	Impeller Exchange Kit (For pump head LPP-4000.5/6)	IEK-4000.2	100-90961	Impeller LPI-4000.1 (A) / O-Ring (B) Pump Casing Screws (C) Pump Motor Screws (D)	ECTFE / O-Ring Kalrez®, 110.7 x Ø3.53 8 pcs. M10 x 40, stainless steel with double washer and protective FPM cover 8 pcs. M10 x 35, stainless steel with PTFE coating
9b	Impeller Exchange Kit (For pump head LPP-4000.7/8)	IEK-4000.5	100-91244	Difference to IEK-4000.2	PFA impeller LPI-4000.4 (instead of LPI-4000.1 ECTFE).
10	ATEX Cable Sealing System	ACS-A.1 (Roxtec)	100-90292	Sleeve (A) and Gasket (B) Frame (C), 2x Cable Module (D)	Stainless steel and EPDM Roxylon (EPDM rubber) Note: Lubricant (E) and measurement plates (F) are included.
11	Eyebolt Seal Set	M16x16 PVDF/FKM	100-90913	Screw / Gasket Material Purpose	M16 x 16 (SW24), PVDF / FKM Chemical protection of lifting eyebolt mounting thread of motor.

Table 4: Specification of accessories

Levitronix® MagLev Pump Technology
Better Pumps for Better Yield!

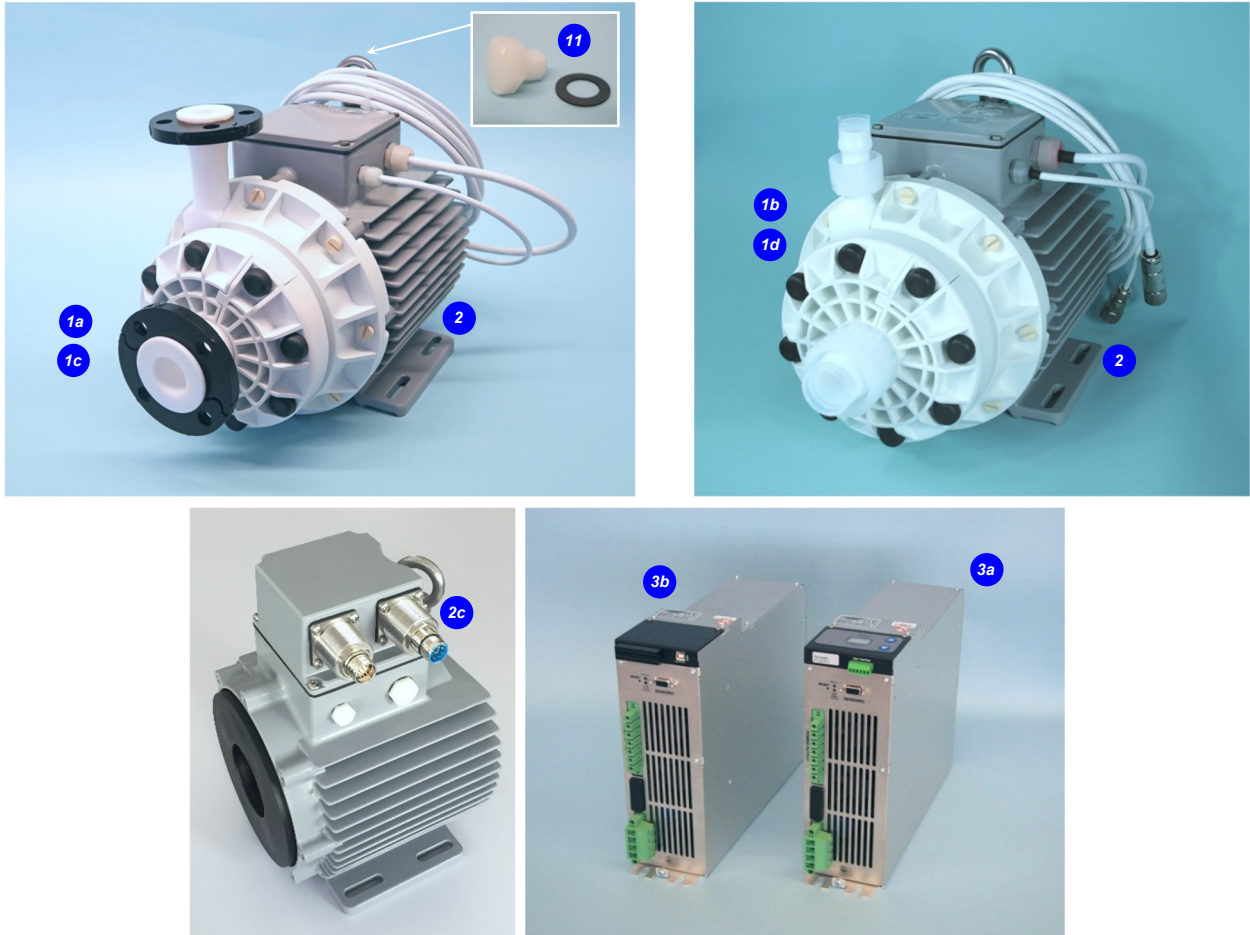

Figure 11: Pump system BPS-4000 with standard components

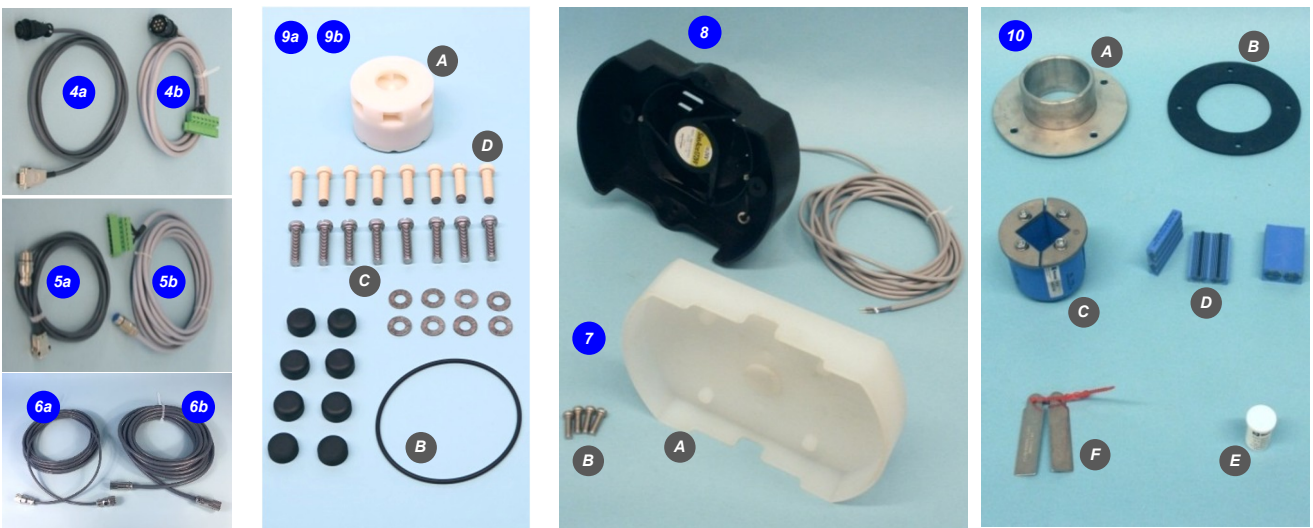

Figure 12: Accessories

**Levitronix[®] MagLev Pump Technology
Better Pumps for Better Yield!**



www.levitronix.com

Bearingless Pump System BPS-4000 MagLev Pumps for Ultrapure Fluid Handling

LEVITRONIX® THE COMPANY

Levitronix® is the world-wide leader in magnetically levitated bearingless motor technology. Levitronix® was the first company to introduce bearingless motor technology to the Semiconductor, Medical and Life Science markets. The company is ISO 9001 certified. Production and quality control facilities are located in Switzerland. In addition, Levitronix® is committed to bring other highly innovative products like the LEVIFLOW® flowmeter series to the market.



Headquarter and European Contact

Levitronix GmbH
Technoparkstr. 1
CH-8005 Zurich
Switzerland

Phone: +41 44 974 4000
E-Mail: salesEurope@levitronix.com

US Contact

Levitronix Technologies Inc.
10 Speen Street, Suite 102
Framingham, Massachusetts 01701
USA

Phone: +1 508 861 3800
E-Mail: salesUS@levitronix.com

Japan Contact

Levitronix Japan K.K.
Wing Eight 5floor, 4-16-4
Asakusabashi, Taito-ku
Tokyo, 111-0053 Japan

Phone: +81 3 5823 4193
E-Mail: salesJapan@levitronix.com

Taiwan Contact

Levitronix Taiwan
5F, No. 251, Dong Sec. 1,
Guangming 6th Rd., Chu Pei City,
Hsin-Chu 302, Taiwan, R.O.C.

Phone: +886 3 657 6209
E-Mail: salesAsia@levitronix.com

**Levitronix® MagLev Pump Technology
Better Pumps for Better Yield!**